

# **495-MW Capacity Genesee Phase 3 Project: The First Supercritical Pressure Coal-Fired Boiler in Canada**

Jody Acton, P. Eng., Hitachi Canada Ltd.  
*Suite 460, 10655 Southport Road, S.W. Calgary, Alberta, Canada,  
Phone +1-403-278-1881/jody.acton@hitachi.ca*

Yoshito Suzuki, Babcock-Hitachi K.K.  
*Takaramachi 6-9, Kure, Hiroshima, Japan  
Phone +81-823-21-1161/suzuki-y@kure.bhk.co.jp*

Yoshio Shimogori, Babcock Hitachi K.K.  
*Takaramachi 6-9, Kure, Hiroshima, Japan  
Phone +81-823-21-1161/shimogori-y@kure.bhk.co.jp*

## **Abstract:**

Hitachi Canada Ltd. (HCL) was contracted by Epcor Power Development Corporation (EPDC) to design and construct the power island for Genesee Phase 3, a 495 MW (gross) capacity coal-fired plant that became operational in January 2005. Hitachi, Ltd. and Babcock-Hitachi K.K. (BHK) were commissioned by HCL to oversee the engineering and construction phases of the Project as well as to provide the major equipment.

This paper presents an overview of the Genesee Phase 3 supercritical-pressure plant, with additional emphasis on the steam generator, which has outlet steam conditions of 25.0 MPa and 570/568°C (superheater outlet pressure and temperature/reheater outlet temperature). The boiler is a supercritical sliding pressure BHK type Benson boiler, and is the first application of this clean coal technology in North America. It achieves high efficiency, flexible operational capability, and excellent reliability while incorporating advanced low nitrogen oxides (NO<sub>x</sub>) combustion technology. The supercritical BHK type Benson boiler design applied to Genesee Phase 3 is from a proven 500-MW class reference plant in Japan.

## **1. Introduction**

Alberta has an abundance of low-cost, low sulfur thermal coal deposits which have historically been used to provide the majority of provincial base-load power requirements. The province has seen consistently strong load growth over the past decade with most capacity additions being combined cycle and/or cogeneration gas turbine-based units. Base load requirements, however, continued to be primarily met with coal-fired and hydroelectric plants with significant increase in the use of natural gas. High natural gas prices, resulting in a significant increase in wholesale power rates coupled with continuing load growth, made addition of coal-fired capacity favorable towards the end of the 1990's.

As any new large scale plant would be merchant-based, and this being the first coal-fired plant to be licensed and constructed in Canada in over a decade, EPDC deemed boiler reliability, environmental performance and the ability to execute an abbreviated construction schedule to be paramount in their supplier selection criteria. Following presentation of a proven reference plant design the Hitachi group was invited to participate in a run-off competition with direct contract negotiations to follow with the preferred supplier. This process was successfully completed culminating with a formal contract execution on December 13<sup>th</sup>, 2001 and notice to proceed on January 9<sup>th</sup>, 2002.

## 2. Supercritical Boiler Development

In a supercritical power plant the steam conditions at the turbine inlet exceed the critical point of water (pressure: 22.1Mpa, temperature: 374 °C). Since 1967, supercritical steam condition units have been installed in Japan, figure 1 showing the trend of steam conditions for coal-fired boilers supplied by BHK. The first coal-fired supercritical boiler of 700MW capacity and turbine inlet conditions of 25.0MPa/543 °C/541 °C started commercial operation in 1983 as shown in Figure 1. In subsequent plants steam conditions were steadily increased in order to increase unit efficiency, reaching the advanced steam conditions of 25.0MPa/570 °C/595 °C for a 500MW coal fired boiler in 1995<sup>(1)</sup>. This boiler would ultimately become the reference for Genesee Phase 3.

Currently supercritical conditions have been applied for numerous units up to 1050 MW in size culminating with the advanced conditions of 25.9MPa/605 °C/613 °C being adopted for the Tachibanawan No. 2 boiler for Electric Power Development Co., Ltd. in 2000<sup>(2)</sup>.

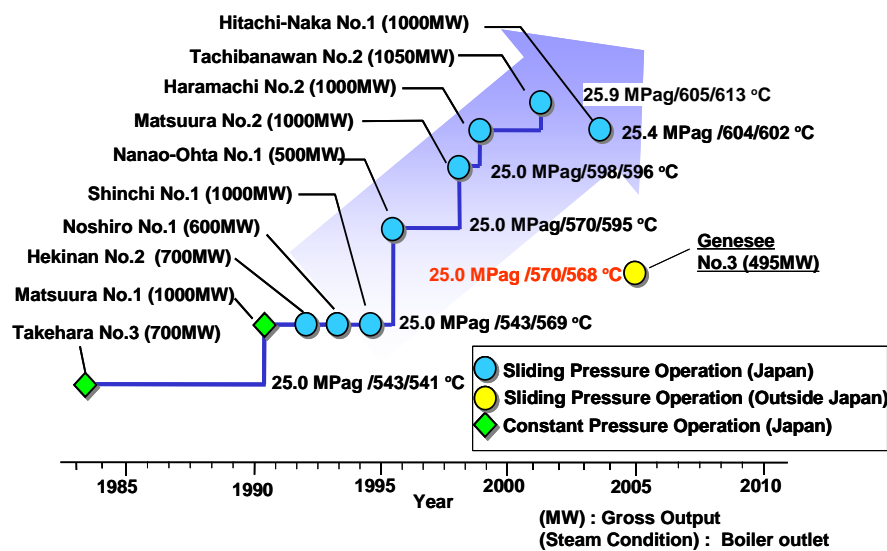

Fig.1 Trend of Steam Condition Improvement

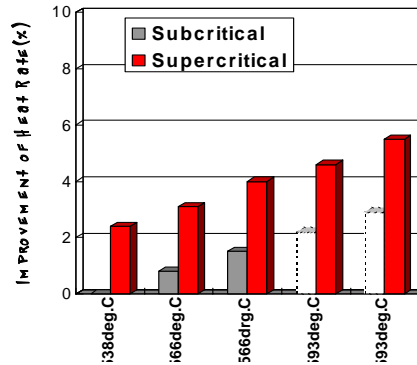

Fig.2 Heat Rate Comparison Super vs Sub Critical Conditions

Figure 2 shows the improvement of heat rate for various supercritical and sub-critical steam conditions. Under the same performance conditions (i.e. fuel properties, ambient temperature, flue gas temperature at air heater outlet temperature conditions, etc), there is no difference in boiler efficiency between subcritical and supercritical, boiler efficiency being largely dependent on combustion-side items such as combustion efficiency, moisture content of fuel, etc. The improvement in plant efficiency using supercritical steam is a result of increased turbine/feedheating cycle efficiency, which results in fuel consumption savings and reduced flue gas emissions per unit output.

### 3. Overview of the Genesee Plant

The Genesee Generating Station and coal mine are located approximately 75 km southwest of Edmonton, Canada. This region hosts four plant sites with a dozen large coal-fired units ranging from 279 MW to 450 MW in capacity. The original Genesee development consisted of two 384 MW units, constructed primarily in the mid to late 1980's, although significant infrastructure for additional units was also installed. The completion of the second, deferred unit in early 1994 marked the end of coal-fired plant construction in Alberta due to major uncertainty in capital cost recovery via rate base application. This unit was also one of the last coal-fired units constructed in Canada.

During the 1990's the provincial economy regained a strong footing and numerous new generation facilities were constructed. These were primarily natural gas fired although wind, biomass and hydro resources were also developed. The province also deregulated the electricity system in the late 1990's and saw a large increase in wholesale power rates due to decreased supply margins coupled with high natural gas prices. These factors led EPDC to reconsider coal-fired capacity due to the low and relatively fixed fuel pricing. An independent study was commissioned by EPDC<sup>(3)</sup> which determined that supercritical pulverized coal combustion was the best available commercially reliable technology for a large-scale coal-fired plant.

Following a preliminary evaluation of suppliers' capabilities, Hitachi was selected to compete in a run-off competition. The major factors for this competition were a) reliability and technical suitability of the boiler design, and b) minimized project schedule. Hitachi's approach to meet

these goals was to adopt a reference plant design for the boiler island, thus minimizing changes and optimizing the construction schedule.

The reference boiler plant selected was Hokuriku Electric's Nanao-Ohta No. 1 unit, a Hitachi design commissioned in 1995. This 500MW boiler had seven years of operation in 2002 achieving 100% boiler reliability on a 24 month turnaround schedule. This despite firing (primarily) high-slagging imported coals. A site visit during a major overhaul was arranged with EPDC's technical lead engineer provided with inspection access. This site inspection confirmed the integrity of the boiler design, and in particular resistance to fly ash erosion as evidenced by the minimal outage work, and was followed by Hitachi being selected as preferred supplier. Only two significant changes were made to the reference boiler design as stipulated by EPDC. The first was to increase the margin for furnace heat release per plan area to reflect the satisfactory operating experience on the existing Genesee boilers. The second was to decrease outlet temperature for the reheat steam. This second change was mandated by EPDC due to the lack of elevated steam temperature experience on the exiting Canadian utility boiler fleet.

Due to Genesee site specific layout constraints a reference plant approach was impractical for the turbine island. The turbine island design and construction were not deemed to pose a significant risk for the project however, due to Hitachi having a reference turbine generator to apply as well as a large market presence and reliable operating record in western Canada. The steam turbine selection was a tandem compound, single reheat, two flow low pressure (LP) design utilizing 40 inch long last stage blades and was based upon the unit installed at Hekinan No. 2 for Chubu Electric Power Co. in Japan. For highest reliability and efficiency Hitachi adopted advanced continuously-coupled blades (CCB) for the LP turbine. The CCB's were also used for the majority of stages in the high pressure (HP) and intermediate pressure (IP) turbines along with advanced profile nozzles.



#### 4. Boiler Plant Fig. 3 Location of Genesee Phase 3 Power Station

For Genesee Phase 3 the design from a previously constructed reference boiler, Nanao-Ohta No.

1 (gross output 500 MW), was applied. The fuel specifications for Genesee and Nanao-Ohta are shown in Table 1 with the main boiler specifications for these two units summarized in Table 2. The reference plant was selected due to the similar steam conditions required coupled with the boiler's excellent availability history.

Table 1 Genesee Phase 3 Coal Specifications

		Nanao-Ohta 1	Genesee 3
Specified Design Coal		More than 100 kinds	Genesee mine
HHV	AD kJ/kg	20,660 – 33,240	19,290
Ash	AF %	1.2 – 20.0	19.4
Fuel Ratio	-	0.9 – 2.4	1.87
Sulfur	AF %	0.2 – 1.5	0.2
Nitrogen	AF %	0.7 – 1.9	0.9
HGI	-	40 - 89	43

Fuel Ratio: *Fixed carbon divided by Volatile matter*  
 AD: *Air Dry Base*      AF: *As Fired Base*

Table 2 Main specification of Genesee Phase 3 Boiler

Item			Specification	
			Nanao-Ohta No.1	Genesee Phase 3
Boiler Type			Babcock-Hitachi Supercritical Sliding Pressure Operation Benson Boiler	
MCR	Steam Flow	Main	1,510 t/h (3,329klb/h)	1,450 t/h (3,197 klb/h)
		Reheat	1,158 t/h (2553klb/h)	1,192 t/h (2,628 klb/h)
	Boiler outlet Steam Pressure	Main	25.0 MPa(g) (3,626psig)	25.0 Pa(g) (3,626psig)
	Boiler outlet Steam Temperature	Main	570 °C(1,058 °F)	570 °C(1,058 °F)
		Reheat	595 °C(1,103 °F)	568 °C(1,054 °F)
Economizer Inlet: Feedwater Temperature			289 °C(552 °F)	284 °C(543 °F)
Combustion System			Pulverized Coal Fired	
Draught System			Balanced Draught System	
Steam Temperature Control System		Main	Water-Fuel Ratio Control Multi Stages Attenuation	
		Reheat	Parallel Gas Dampering Spray Attenuation (Emergency)	
Steam Temperature Control Range		Main	28% MCR to MCR	35% Load to MCR
		Reheat	50% Load to MCR	50% Load to MCR

MCR: Maximum Continuous Rating

#### 4.1 Boiler Design Features

The side view of the boiler is shown in Figure 4, the type being a BHK supercritical

Benson Boiler. The detailed design features and the benefits of Benson boiler are described in the related papers<sup>(4)(5)</sup>. The design features of Genesee Phase 3 boiler are as follows:

- 1) A spiral water-wall construction using internal rifled tubing combined with an opposed firing system is adopted in the lower part of the furnace. It is designed to minimize imbalance of fluid temperatures at the furnace water-wall tube outlet for reliable operation.
- 2) The heating surface arrangement is optimized such that steam temperature is efficiently controlled over the operating range.
- 3) The downpass section utilizes a parallel gas damper system which controls reheater outlet steam temperature by biasing the gas flow passing through the primary reheater. This results in improved controllability and responsiveness of reheat steam temperature and enables elimination of gas recirculation which had been installed in previous Benson boilers.

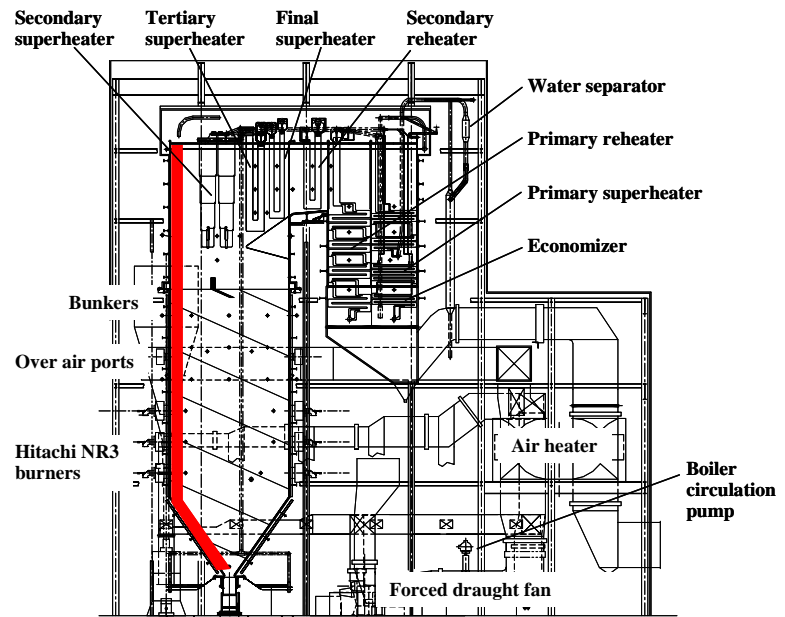

Fig. 4 Side View of Genesee Phase 3 Boiler

- 4) A steam separator and a drain tank are installed for a smooth changeover from the circulating mode to the once-through mode following the start-up.
- 5) The combustion air and flue gas system is a single train comprised of a single forced draft fan (FDF), a primary air fan (PAF), an induced draft fan (IDF) and a single tri-sector air heater. This configuration has been established and confirmed in the 500MW reference unit, which now has more than 10 years of successful operation.
- 6) Sliding pressure operation is introduced whereby the main steam pressure is controlled in proportion to the generation output. To keep the turbine-governing valves open, and thus

Figure 4 Side view of Genesee Phase 3 Boiler

minimize throttling losses, steam pressure at the turbine inlet can be changed to keep constant volume flows. Compared with constant pressure operation, sliding pressure operation improves thermal efficiency of the steam turbine at partial loads by decreasing thermodynamic losses.

- 7) Two-pass design with a sufficient cross-section in the downpass which results in uniform gas velocity distribution and minimizes ash channeling. This type of two-pass boiler has two 90 degree turns in the gas pass instead of one 180 degree turn, a key point in avoiding severe localized erosion. The net effect is the ability to burn high-ash content fuels with minimized erosion.

## 4.2 Spiral Wall Furnace

For sliding pressure once-through boilers, the fluid mass velocity through the wall tubes during low load and low-pressure operation tends to be closer to the critical mass velocity point than for constant high-pressure boilers at low load. It is important for reliability and tube life to maintain a certain level of high mass velocity in the tubes and to keep uniform heat absorption rates across the entire furnace. Therefore, the BHK type Benson boiler furnace is constructed with a spirally wound water-wall arrangement. One reason for this is that when the inclined tube is applied, the tube number is reduced, because the same tube pitch is necessary for better cooling of the membrane bar. Therefore, the mass velocity in the tubes is increased compared with vertical tubes. The other reason is that the spiral wall is designed so that the fluid path wraps the walls of the furnace and minimizes differences in heat absorption, as shown in Figure 5. The net result is a uniform fluid temperature profile across the full range of boiler loads. An added benefit of the spiral water wall system is that flow adjusting devices such as orifice plates are not required; these requiring on-going maintenance to avoid tube failures.

In addition to the spiral wall configuration, internally ribbed tubes (rifled tubes) are used to reduce the temperature difference between the fluid and the tube wall of the furnace, by suppressing DNB (departure from nucleate boiling) in the sub-critical pressure region and pseudo-film boiling in the supercritical pressure region.

## 4.3 Main and Reheat Steam Temperature Controls

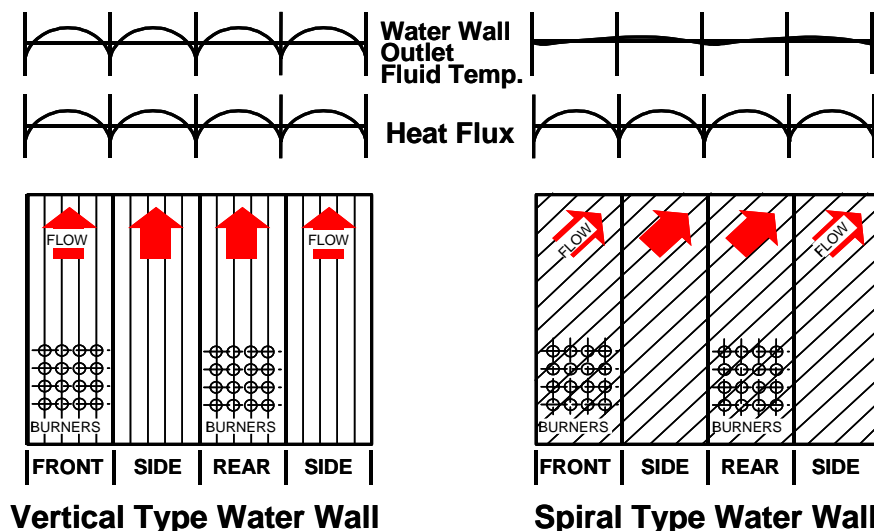
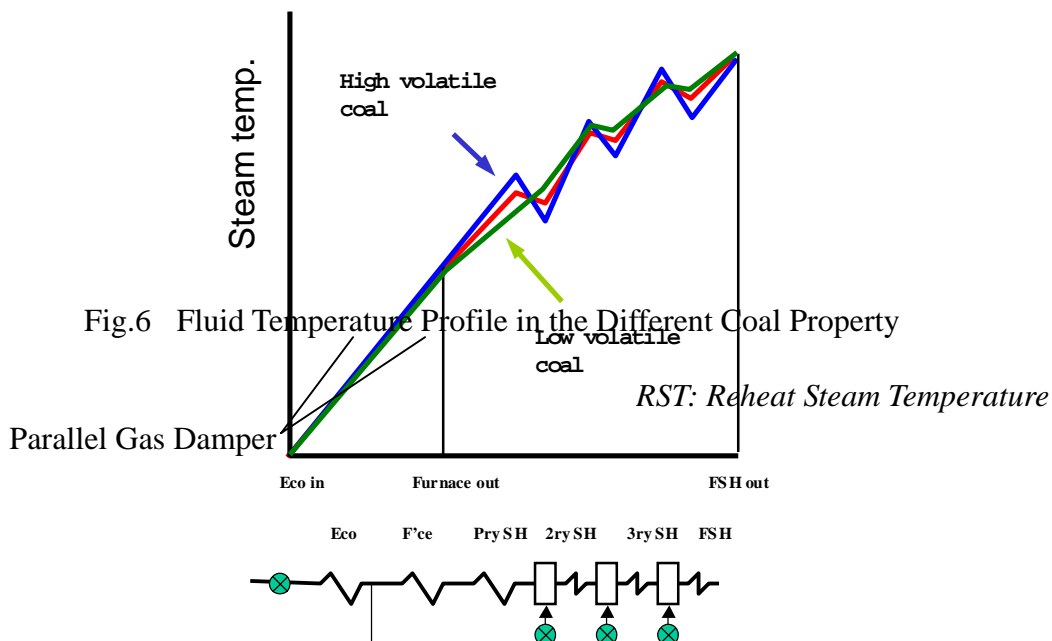

Fig.5 Spiral Wall Keeping Uniform Temperature at the Outlet

Combustion and slagging characteristics changes caused by different coal properties leads to different heat absorption rates in the furnace, and hence different temperature profile conditions through the boiler. Even when firing coal from the same mine, as is the case for the Genesee plant, coal properties can change significantly during operation. The differences in steam profiles caused by firing coals with different combustibility properties are shown in Figure 6.

Due to furnace exit gas temperature excursions and heat absorption rate differences caused by changing coal characteristics, main steam temperature control is important to maintain constant steam outlet conditions and to protect the turbine. The only method available to control the main steam temperature on a conventional subcritical boiler is superheater spray attemperation. This is because saturation conditions are fixed at the drum and the furnace fluid conditions are adjusted accordingly by natural (or forced) circulation. For the BHK type Benson boiler, the principal control method for main steam temperature is control of the water to fuel ratio. Multi-staged superheater spray attemperation is used only for the adjustment of heat absorption characteristics due to variation in coal properties (i.e. secondary control means). Therefore, the Benson boiler is inherently more flexible than conventional subcritical boilers for changing coal properties and differences in slagging characteristics. Japanese coal fired plants are highly experienced with this steam temperature control technology, because of the many different types of coal that are imported from various countries in the world.

For reheat steam temperature control, a parallel damper gas biasing system is applied to maintain the rated steam temperature over a wide load range without utilizing spray water attemperation. This control method is highly effective even for firing various kind of coal with different combustion properties. These provisions can assist the turbine plant in maintaining a



low heat rate (Figure 7).

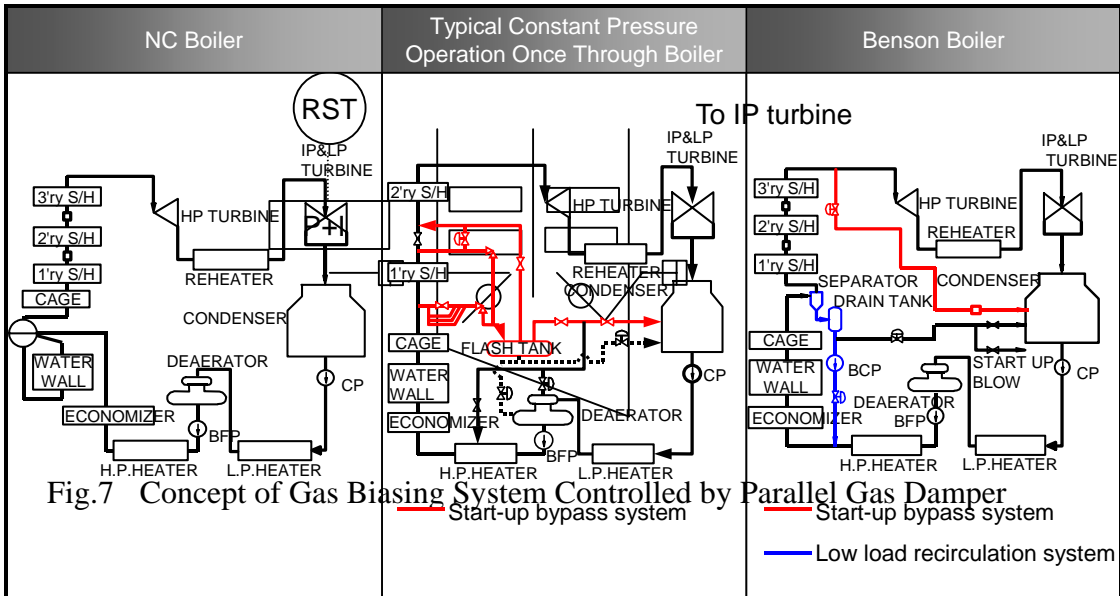

#### 4.4 Start-up system

As shown in Table 3, the Benson boiler includes a circulation system that consists of a steam separator and boiler circulation pump, which allows stable and straightforward operation during start-up and shutdown. This circulation system provides smooth operation equivalent to a natural circulation boiler during start-up and shutdown. Even in the case of the boiler circulation pump outage, which is unlikely, the boiler can also be started by using the line from drain tank to condenser.

The allowable minimum load of the Benson boiler is between 25% to 35% during once-through operation and 15% in circulation mode. The start-up period is also significantly shortened compared to a constant pressure boiler.

Table 3 Start-up System for Different Boiler

#### 4.5 Combustion Systems

To reduce NO<sub>x</sub> produced during combustion without degrading combustion efficiency, Hitachi developed the advanced NR-type burner. With this burner an innovative concept, in-flame NO<sub>x</sub> reduction, was applied with BHK progressively developing the technology in the subsequent NR2 and NR3 burners. These burners strengthen flame stability with a flame stabilizing ring with the high temperature flame achieving very low levels of NO<sub>x</sub> with high combustion efficiency<sup>(6)</sup>. The most advanced NR3 burner has been applied to Genesee Phase 3, the second installation in a new coal-fired unit. The development history, configuration, and performance of the Hitachi NR burner series are shown in Figure 8.

Regarding coal pulverizers, the newest MPS type system, HP (High Grinding Pressure) has been applied to Genesee Phase 3. In the MPS HP type, the capacity is increased from about 20% to 50% compared to the previous design by controlling the grinding pressure and rotating speed of the grinding table.

#### 4.6 Advanced Boiler Plant Design Consideration Process

PDM (Product Data Management) is a system for effectively managing the large volume of data that flows back and forth during the lifecycle of a plant, from design to fabrication and construction, and then on-going maintenance. To improve project performance by streamlining engineering, reducing costs, and shortening the project schedule, the PDM system and a sophisticated Plant Design System (PDS) were adopted from the early stages of the project. The Genesee Phase 3 project was the first application of this approach and proved very effective in customizing the boiler. Figure 8 illustrates the evolution of the Hitachi NR burner series (Figure 9) with improvement.

All information regarding the boiler proper, boiler auxiliaries and related equipment, external

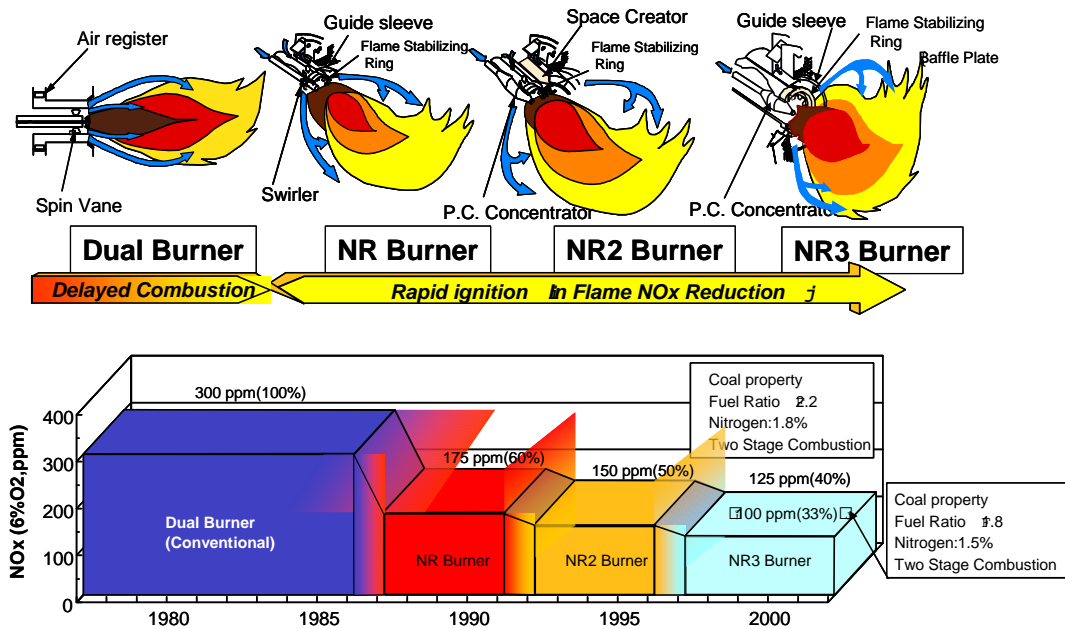

pressure parts and piping, supports, structural steel, and the like was entered into the plant design system. Access to this data and its utilization were facilitated at every step of the project including layout management, production design, design change tracking, materials control, site preparation, and installation work.

#### **4.7 Simultaneous Construction**

Simultaneous construction method has been refined by Hitachi since the early 1990's and was applied to a coal-fired project in North America. This enabled project completion – from NTP (Notice to Proceed) to S/C (Substantial completion) – in a shorter period than the typical NAFTA region experiences.

As illustrated in Figure 10, simultaneous construction involved delivery and installation of boiler pressure parts, ductwork, coal silos, piping, supports, valve stations, and other ancillary equipment in parallel with structural steel erection. To successfully apply this simultaneous approach, delivery of equipment, system components and bulk materials must be managed while the structural steel is being erected. For this Genesee Phase 3 project, several local trade-specific construction vendors were involved with our implementation of this construction method. The primary advantages of simultaneous construction are:

- a) Use of temporary scaffolding and equipment can be minimized because most of the components are installed from above. This reduces the amount of work in high places (“height work”), which improves safety and production.
- b) Installation can proceed in parallel with excavation and earthwork, and work area congestion is reduced. This not only improves work efficiency but also reduces the overall construction process by reducing the number of times that large equipment such as mobile cranes must be mobilized.

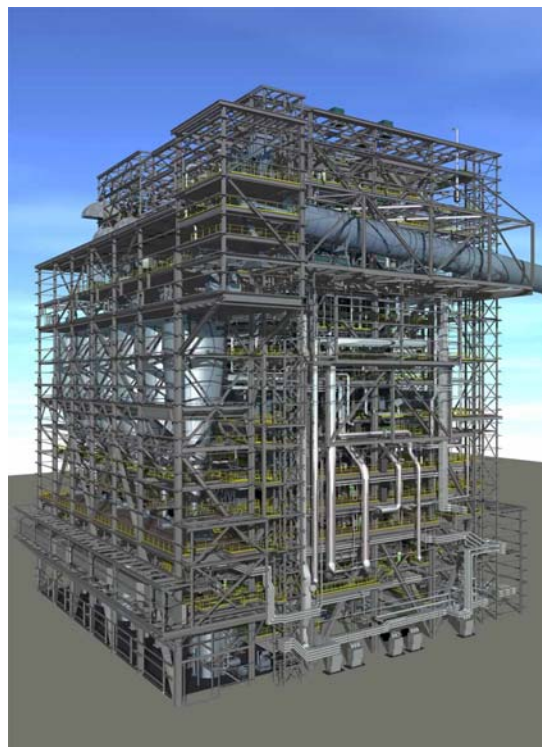

“Floor unit construction” is an important component of simultaneous construction. Lugs, anchor points, and the like, for the various pieces of equipment are welded to the structural steel beams in advance while the beams are assembled into horizontal floor units. Handrails, gratings, ducts, piping, etc. are all laid out on the floor units and then hoisted into position, between the pre-installed columns as a single assembly. This enables a majority of the work to be done at ground level, and also permits typically 20 to 30 component pieces – a combination of beams and



equipment – to be lifted into place all at the same time.

## **5. Results of Commissioning Operation**

Since the unit start-up period, boiler operation has been stable and reliable. The main features of boiler performance are summarized as follows;

### **5.1 Boiler Performance**

Figure 11 shows the steam and water temperature and pressure characteristics at each load. Steam pressure rises in accordance with boiler load as expected and the main steam and reheat steam outlet temperatures are consistent and uniform across the load range at their design rating of 566°C. The temperature stability for main steam and reheat steam at 100% load are shown in Figure 12 and verify very stable operation including during sootblower operation. Boiler efficiency was confirmed to be higher than expected at full load.

### **5.2 Load Change Characteristic**

Fig.10 Simultaneous Construction of Boiler in Genesee Phase 3

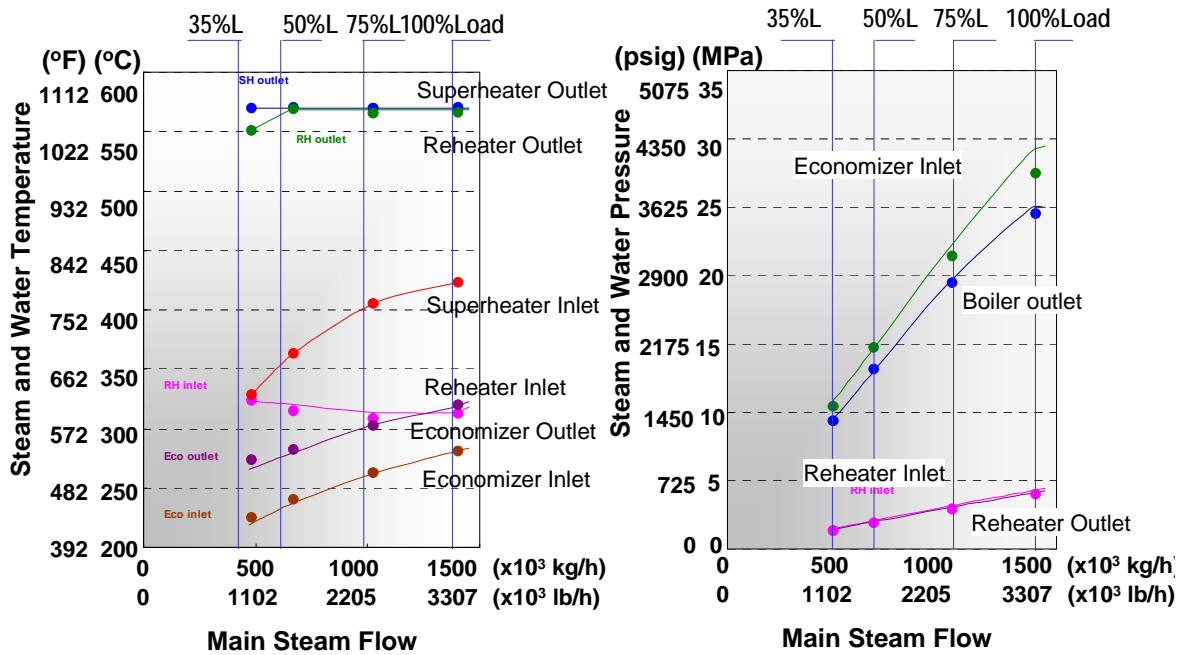

The load change characteristics of the boiler are shown in Figure 13. Due to the well established main steam and reheat steam temperature control, stable temperatures within the allowable tolerance were confirmed with sliding pressure condition.

### 5.3 Minimum Load Operation

Minimum load achievable during coal firing without support fuel for Genesee Phase 3 is 35% load. During minimum load operation very stable unit output as well as consistent main steam and reheat steam outlet conditions were confirmed. In spite of this result, EPDC have decided that operational constraints require the minimum load to be held a little higher.

Fig.11 Steam Temperature Characteristics at 100% Load (Jan 11 '05)

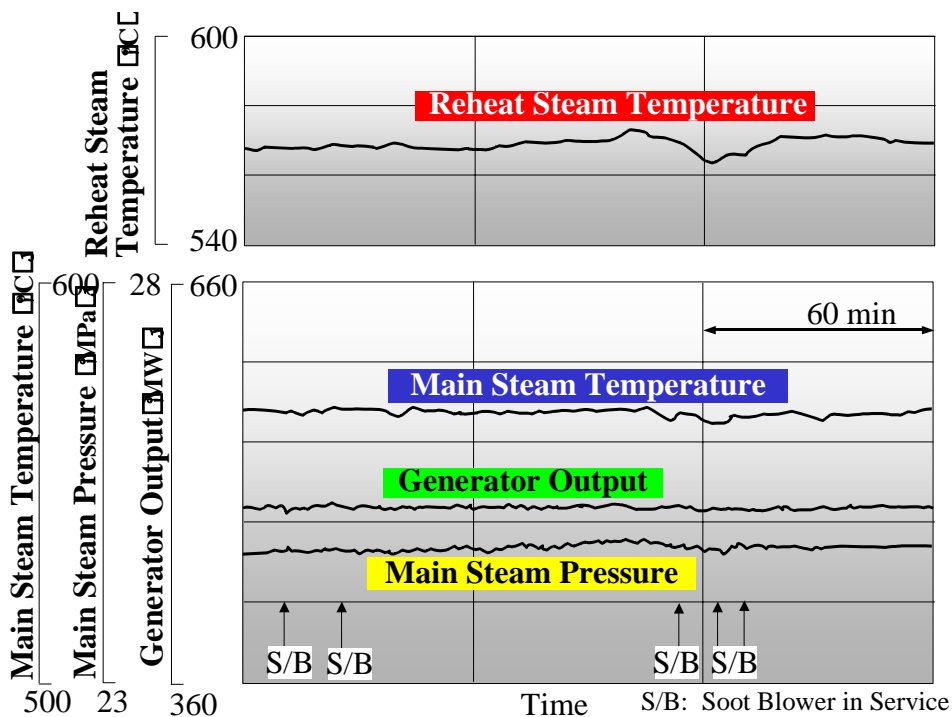

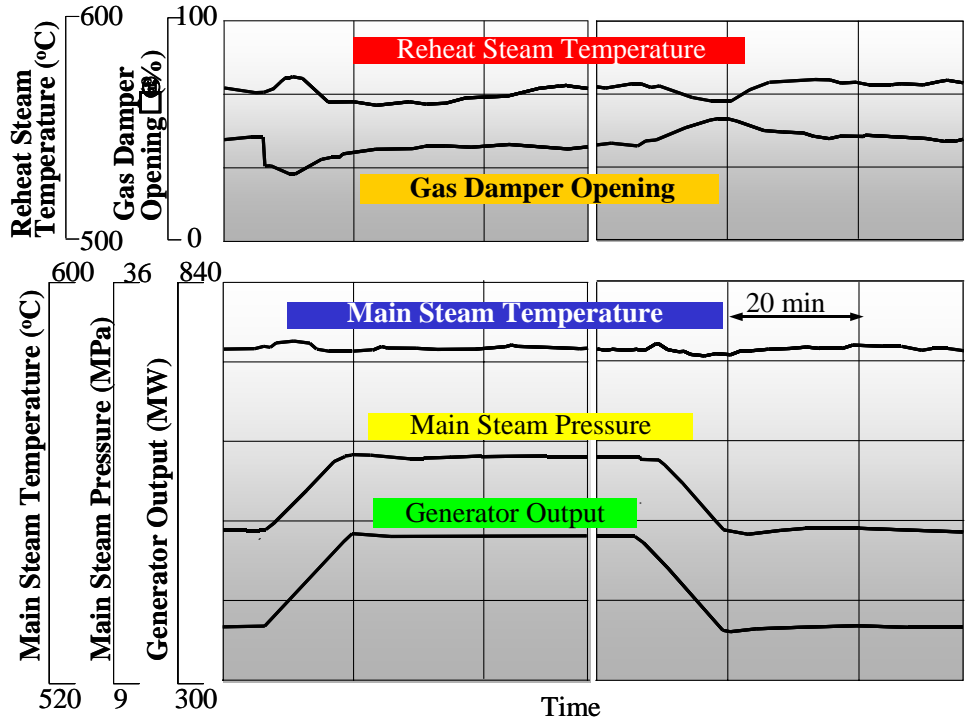

Fig.12 Boiler Characteristics at 100% Load

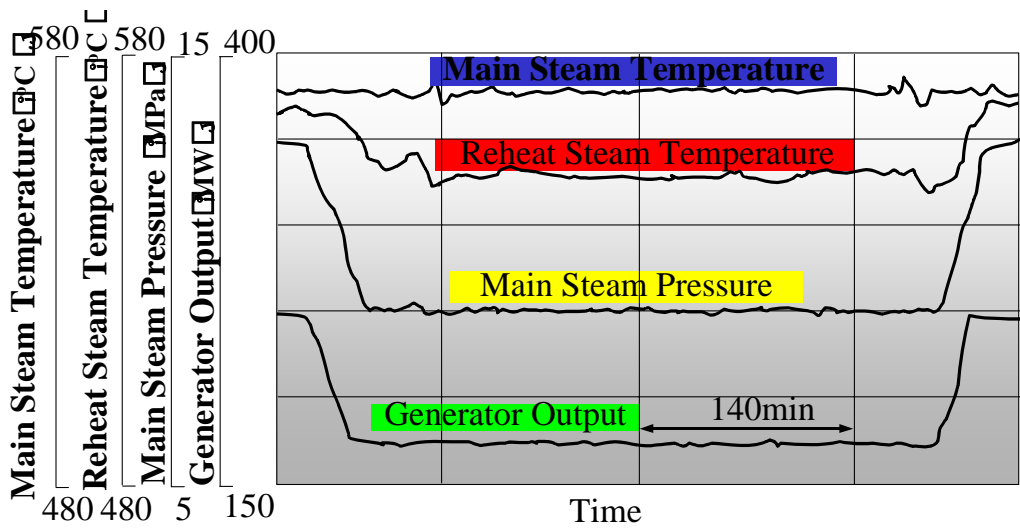

Fig.14 Result of Minimum Load Test at 35% Load

Fig.13 Result of Load Swing Test (2%/min, Jan 6, 2005)

## 5.4 Combustion Performance

Genesee Phase 3 is equipped with the latest developed Hitachi NR-3 burner. The results of combustion testing were excellent with extremely low NO<sub>x</sub> values (without SCR), approximately 15-25% below the guarantee value. This was achieved while maintaining an extremely low level of unburned carbon in ash. Figure 15 shows the burner flame with typical



Fig.14 Result of Minimum Load Test at 35% Load

Fig.14 Result of Minimum Load Test at 35% Load

Fig.15 Hitachi NR 3 Burner Flame  
at Minimum Load

Genesee coal fired at minimum load (35% load with no support firing). A very bright and stable flame was maintained at the tip of the burner nozzle.

## 6. Summary

Genesee phase 3, a 495MW capacity coal fired power plant near Edmonton, Alberta, is the first supercritical pressure power station built in Canada. It commenced commercial operation on March 1, 2005 and set a new benchmark by applying supercritical Benson Boiler for coal fired power plants. The Genesee Phase 3 unit halves the NO<sub>x</sub> emissions levels of the existing local coal-fired plants while maintaining economic competitiveness as merchant plant with full dispatch capability.

This newly instilled unit is also the first sliding pressure type coal fired supercritical unit in North America. The design is based upon the extensive experience with supercritical pressure pulverized coal combustion technology developed to a fully-mature state by the Hitachi group. The plant combustion system design, including furnace and heating surface was adjusted from the reference plant to meet the characteristics of western Canadian sub-bituminous coal. The excellent commissioning results are confirmed; reliable operation keeping stable supercritical steam conditions, high efficiency and low emission combustion, and flexible operation including low minimum load and rapid load changing capability.

## References

- 1) J. Matsuda, A. Teshima, et al.: Latest Design and Experience of Coal Fired Benson Boiler, Fourth International Conference on Technologies and Combustion for Clean Environment, Lisbon-Portugal (7-10, July, 1997)
- 2) H. Iwamoto, J. Matsuda et al.: Experiences in designing and operating the latest 1,050 MW coal-fired boiler, Hitachi Review Vol.50 (2001), No.3 pp100-104
- 3) D. Conlin P Eng,: Canada's First Supercritical Pressure Coal Fired Generating Unit, Canada Power 2004 Conference, Toronto, Canada (Sep. 2004)
- 4) K. Saito, M. Richardson, et al.: Reliability of Supercritical Boiler and its Advantages, Electric Power Conference 2004, Baltimore, MD, USA (31 April 2004)
- 5) Y. Kidera, M. Richardson et al : Supercritical Boiler Technology Matures, Coal-Gen 2004, KS, USA (28-30 July 2004)
- 6) T. Yano, K. Sakai, et al : Updated Low NOx Combustion Technology for Boilers, 2003 Combined Power Plant Air Pollutant Control Mega Symposium, Washington DC, USA (19-22 May 2003)