

# H-25 Gas Turbine

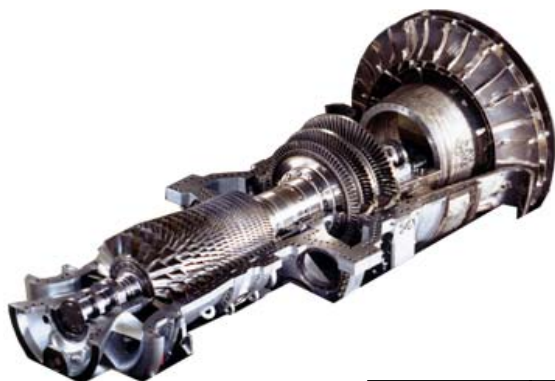

H I T A C H I P O W E R S Y S T E M S A M E R I C A , L T D .



Hitachi has developed the **H-25 Gas Turbine** with technological advances based on more than 30 years of experience producing more than 400 heavy duty gas turbines.

- 33.8% Thermal Efficiency
- High Reliability
- Low O&M
- Short Delivery Cycle
- High Fuel Flexibility
- Modular Design

The H-25's competitive capital cost, high fuel flexibility, short delivery cycle and high thermal efficiency make it an economical solution for your power needs. Through the utilization of state of the art technologies, the H-25 operates with a high exhaust temperature while maintaining a high efficiency. These performance characteristics make the H-25 an excellent choice for cogeneration and combined cycle facilities.

The H-25 is designed to be a cost effective modular replacement for existing MS5001 gas turbines. The cost for replacement can be paid off in a short time period with the fuel savings from the higher efficiency and additional revenue from the higher output.

## H-25 Simple Cycle Performance

		Natural Gas	Distillate Oil
Output	KW	27,500	26,300
Efficiency	% (LHV)	33.8	32.6
Heat Rate	Btu/kWh (LHV)	10,097	10469
Air Flow	lb/sec	194	194
Exhaust Temp	Degrees F	1031	1031

ISO Conditions  
Inlet Pressure Drop: 3.5" H2O  
Exhaust Pressure Drop: 2.5" H2O

## H-25 Emissions

Combustor	Fuel	NOx Abatement	Injection Flow, kpph	NOx, ppm (15%O2)	NOx with SCR, ppm (15% O2)
Standard	Natural Gas	-	0	188	19
		Steam	17.4	53	5
		Water	20.9	25	2.5
	Distillate Oil	-	0	264	26
		Steam	17.4	74	7
		Water	20.9	42	4
Single Fuel LNC	Natural Gas	Dry	0	25	2.5
Dual Fuel LNC	Natural Gas	Dry	0	25	2.5
	Distillate Oil	Water	20.9	42	4

ISO Conditions  
90% NOx Removal Efficiency of SCR



# HITACHI POWER SYSTEMS AMERICA, LTD.

## Typical 2025 Combined Cycle Power Plant

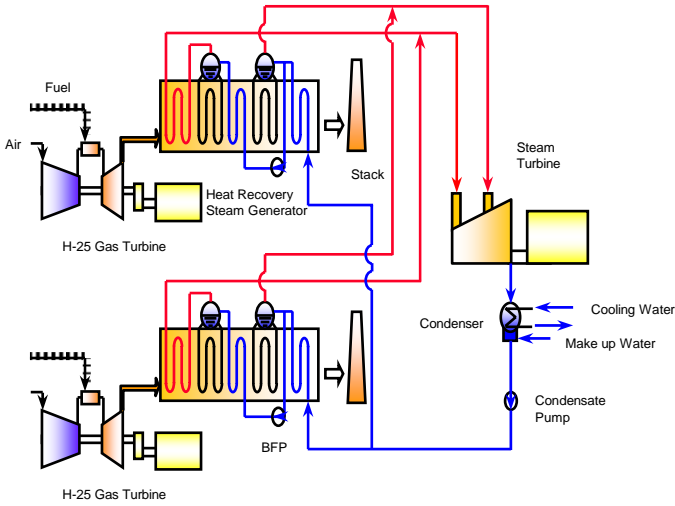

Hitachi Power Systems America, Ltd.  
 645 Martinsville Road  
 Basking Ridge, NJ 07920  
 (P) 908-605-2800  
 (F) 908-604-6211  
 power.info@hal.hitachi.com

## H-25 Experience

No.	Customer	Application	Fuel Type	CO Date	Op. Hours
1	Idemitsu Kosan	Cogen.	Gas/Oil	Nov. 88	103,395 (Nov. 01)
2	General Sekiyu (J.V. Exxon)	Cogen.	Gas/Oil	May 89	93,681 (June 01)
3	Tsurusaki Kyodo	Cogen.	Gas/Oil	Feb. 90	89,006 (Nov. 01)
4	Hitachi, Ltd.	IMD	Oil	May 93	6,325 (Feb. 02)
5	Showa Yokkaichi (J.V. Shell)	Cogen.	Dual Gas	June 96	40,457 (July 01)
6	Showa Yokkaichi (J.V. Shell)	Cogen.	Dual Gas	Aug. 96	39,571 (July 01)
7	Tsurusaki Kyodo	Cogen.	Gas/Oil	Oct. 97	35,420 (Jan. 02)
8	General Sekiyu (J.V. Exxon)	Cogen.	Gas/oil	Sept. 97	30,932 (June 02)
9	Hitachi, Ltd.	C/C	Oil	Jan. 98	28,408 (Jan. 02)
10	Hitachi, Ltd.	C/C	Oil	Mar. 98	28,065 (Jan. 02)
11	LGPC (Korea) (LG Petrochemical Co. Ltd.)	Cogen.	Gas	Sept. 00	14,062 (May 02)
12	Urea Fertilizer Factory Ltd.	Cogen.	Gas	July 01	2,000 (Nov. 01)
13-18	Sask Power (Canada)	C/C (6 units)	Gas	2002	1,500 (Feb. 02)
19	FPPC (Philippine) (First Private Power Corporation)	C/C	Gas/Oil	2003	-
20-25	NEAP (Nigeria) (National Electric Power Authority)	S/C (6 Units)	Gas	2001	1,000 (Feb. 02)
26	Bahama Electricity Corp (Bahama)	S/C	Oil	2002	-
27	Petrobras (Brazil)	Cogen.	Gas	2003	-
28-32	SEGAS/KJT (Egypt) (Union Fenosa)/(Kellogg/JGCT/Tecnicas)	S/C (5 Units)	Gas	2003	
33	Abu Dhabi Oil Company Ltd. (UAE)	S/C	Gas	2004	

[www.hitachi.us/hpsa](http://www.hitachi.us/hpsa)

**HITACHI**  
 Inspire the Next